

VISY-X

VPI

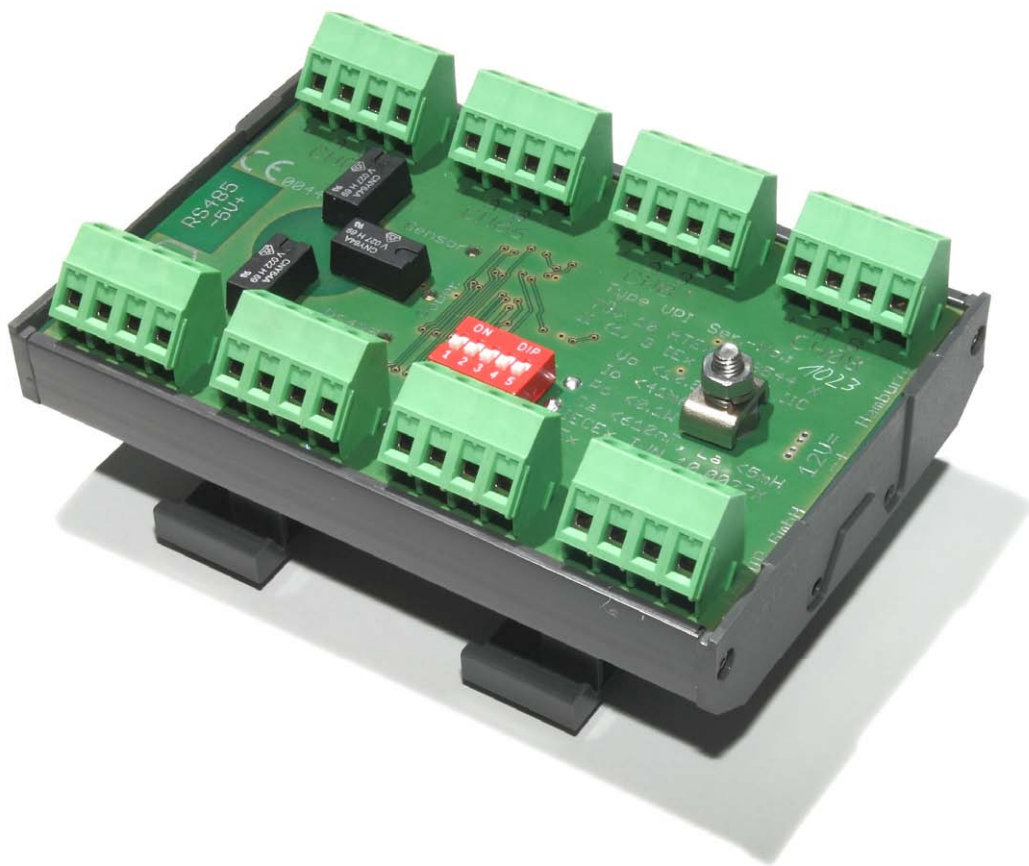

Edition: 07/2011
Version: 1
Article no.: 350068

Table of contents

1	Introduction.....	3
1.1	In this manual.....	4
1.2	Requirements for service engineers.....	4
1.3	Safety instructions.....	5
2	Design and operation.....	6
3	Installation.....	7
3.1	Installation.....	7
3.2	Connection of the sensors.....	7
3.3	Interface connection RS-485.....	8
3.3.1	Programming interface.....	9
3.3.2	Configuration of the VPI address.....	9
3.4	Connection of the supply voltage.....	9
3.5	Status LEDs.....	10
4	Technical data.....	11
4.1	VPI.....	11
4.2	VPI--Supply.....	12
5	List of figures.....	13
6	List of tables.....	13
7	Annex.....	14
7.1	Operating instructions VPI transducer.....	14
7.2	EC-type examination certificate - VPI.....	17

© Copyright:

Reproduction and translation is only permitted with the written consent of FAFNIR.
FAFNIR reserves the right to carry out product alterations without prior notice.

1 Introduction

The VISY-X system (**V**olume **I**nformation **S**ystem) provides highly precise and continuous filling level measurements for all commercially available fuels. With the VPI Interface (VISY Power Interface), a filling level measurement can be taken in up to 256 tanks using a maximum of 32 VPIs. The product temperature and water level are measured simultaneously and the density can also be measured as an option.

The system includes:

- the VPI as a communication interface between the sensors and a higher-level system (host)
- the FAFNIR VPI power supply (Art. no. 908315). As an option, an independent power supply can also be used, see chapter 3.4
- the VISY-Stick and/or VISY-Reed sensors
- as an option, the VIMS sensors from our system partner SGB (see chapter 1.1) can also be connected

The sensors are connected with the VPI which is mounted inside the petrol station building.

The VPI is a communication interface between the sensors and a higher-level system (host). Commands from the higher-level system to the sensors are allocated to the corresponding sensor terminals of the VPI. The feedback from the sensors is transmitted back to the higher-level system (host).

The VPI supports the following protocols:

- FAFNIR Universal Device Protocol (UDP)
- H-Protocol



In order to take advantage of all functions offered by the VISY-X system, the FAFNIR Universal Device Protocol must be used.

1.1 In this manual...

... you will be guided through the installation and set-up of the VPI interface.

These instructions contain a description of all the steps needed to perform the installation. Please also observe the additional instructions in the following documents:

- Technical Documentation VISY-Stick VISY-Reed (English) – Art. No. 207194
- Technical Documentation FAFNIR UDP (English) – Art. no. 350052

For the installation of the VIMS sensors, please also contact:

- SGB GmbH, Hofstraße 10, 57076 Siegen, Germany
Tel.: +49 271 48964-0, Fax: +49 271 48964-6, e-mail: sgb@sgb.de

1.2 Requirements for service engineers

The complete VISY-X system should only be installed by trained service engineers.

1.3 Safety instructions

The VISY-X system is optimised for use in petrol stations and is compatible with all commercially available fuels. It serves as measuring and analysing the filling levels in the tanks. The system must be used exclusively for this purpose. Please observe and follow all product safety notes and operating instructions. The manufacturer accepts no liability for any loss or damage arising from improper use.

The VPI interface has been developed, manufactured and tested in accordance with the latest good engineering practices and generally accepted safety standards. Nevertheless, hazards may arise from their use.

The following safety precautions must be observed in order to reduce the risk of injury, electric shocks, fire or damage to the equipment:

- Please do not make any changes to the system.
- The installation, operation and maintenance must only be carried out by expert personnel.
- Operators, installers and service technicians must comply with all applicable safety regulations. This also applies for local safety regulations and accident prevention guidelines, which are not included within these operating instructions.
- During the installation process, valid national construction regulations must be observed.
- The VPI must not be installed in potentially-explosive areas.
- The VPI must be in a clean and undamaged condition at all times.
- The VPI must only be powered by the permissible auxiliary power supply.

The safety instructions in this manual are labelled as follows:



Failure to observe these safety instructions runs the risk of potential accidents and damage to the VISY-X system.



Useful tips and information in this manual to be observed are written in italics and identified by this symbol.

2 Design and operation

The VPI is designed for the DIN mounting rail.

It has eight intrinsically safe sensor terminals. At each individual sensor terminal of the VPI, it is possible to connect up to three different types of FAFNIR sensors (e.g. one VISY-Stick, one VISY-Stick Interstitial and one VISY-Stick Sump). These three types of sensors can be directly connected to each other at the measuring point. This means that only one cable (4-wire) is required for connection to the VPI interface.



In combination with the VIMS sensors from our system partner for leakage control (SGB GmbH, Siegen), two FAFNIR sensors and two SGB sensors can be connected to the VPI using one single cable (4-wire).



Connecting multiple sensors of the same type (e.g. 3 x VISY-Stick) to one sensor terminal is not permitted.

The sensors are electrically supplied with power by the VPI. A 12 V direct current is necessary for the power supply of the VPI. The FAFNIR VPI-Supply (accessories) is safely galvanically isolated between the input and output and can supply up to two VPIs.

Alternatively, another power supply can be used. Therefore, a power consumption of 125 mA should be set for every VPI. The tolerance of the supply voltage must not exceed 5 %.

Depending on the number of sensors to be connected, up to 32 VPIs may be interconnected. Every VPI must hereby be assigned with its own address from 0 to 31 via a DIP switch.

3 Installation

 For the installation and operation of the interface VPI in Germany, the requirements of the Ordinance on Explosion Protection (ExVo), the Ordinance on Industrial Health and Safety (BetrSichV) and the equipment safety legislation must be observed (in other countries, equivalent local requirements and regulations must be observed). In all countries, valid and generally accepted good engineering practices as well as these operating instructions must be observed.

 All applicable local safety regulations and accident prevention guidelines not included in these operating instructions must also be observed.

 All wiring operations must be carried out with the power disconnected.

3.1 Installation

 The VPI must be firmly connected inside a building to a mounting rail in a casing with a protection class of at least IP20.

 *In casing with the corresponding protection class (at least IP54), the VPI is also suitable for outdoor installation.*

3.2 Connection of the sensors

Connect the sensors to the sensor terminal clamps of the VPI (see Figure 1).

The connection cable of the sensors must have the following properties:

- 4-wire, unshielded cable, oil-resistant
- Line cross section (4 x 0.5 mm² up to 250 m or 4 x 1.0 mm² over 250 m)
- All blue or with blue markings (cable for intrinsically safe electric circuits)

 **The maximum external inductance including the cable must not exceed 5 mH and the maximum capacitance must not exceed 610 nF (see data sheet of the used cable).**

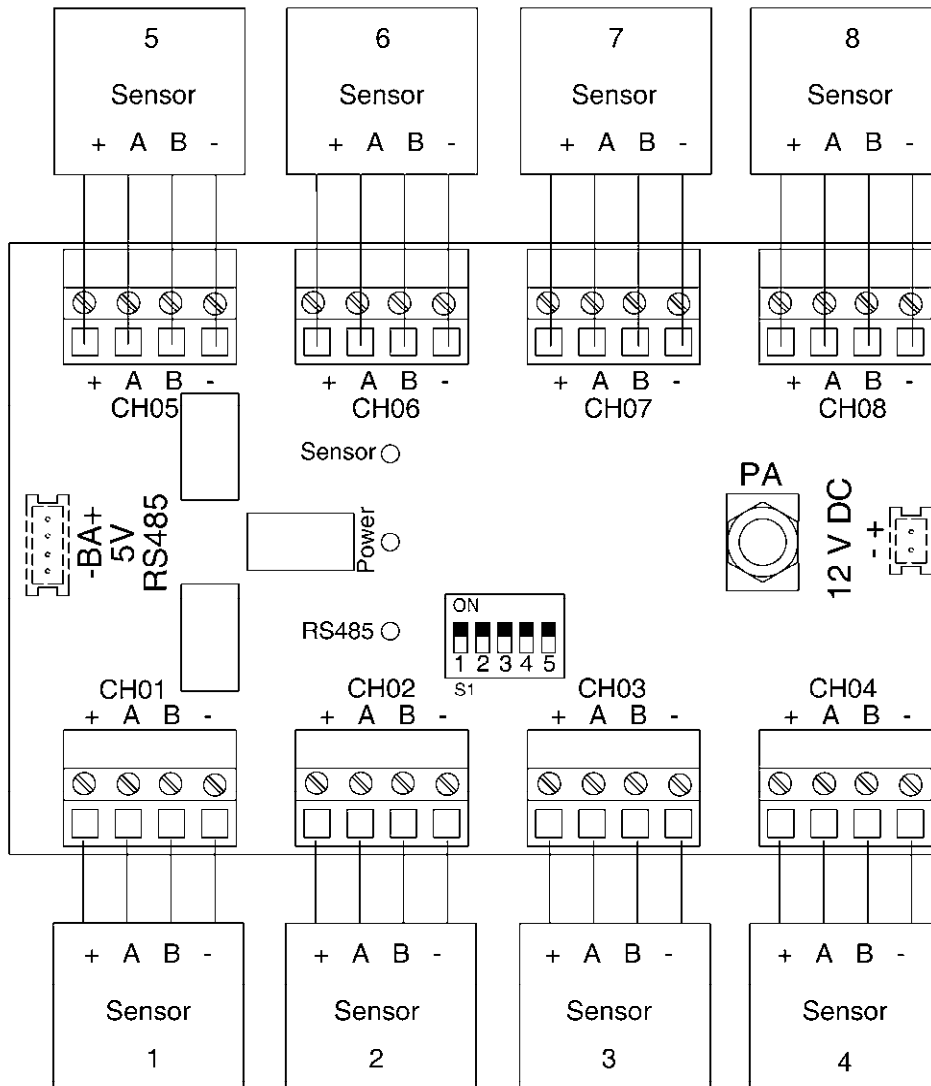

Figure 1: VPI terminals

3.3 Interface connection RS-485

In order to connect to the higher-level system (host), the VPI has a RS-485 interface with a 4-pole header plug on the underside of the board. The interface does not have its own power supply and must be supplied with 5V via the accompanying 4-pole connection cable.

Two transmission speeds are supported:

Baud rate	Data bit	Stop bit	Parity
1200	8	1	none
4800	8	1	none

3.3.1 Programming interface

Concealed at the back of the printed circuit board is a programming interface through which an update of the VPI firmware can be carried out if necessary. For more information, please contact FAFNIR.

3.3.2 Configuration of the VPI address

Up to 32 VPIs can be interconnected for the connection of the sensors. Every VPI must be assigned with its own address from 0 to 31. The addresses are configured by the sum of powers of 2 with the DIP switch S1.

DIP switch S1	1	2	3	4	5
VPI address	$2^0=1$	$2^1=2$	$2^2=4$	$2^3=8$	$2^4=16$
0	OFF	OFF	OFF	OFF	OFF
1	ON	OFF	OFF	OFF	OFF
2	OFF	ON	OFF	OFF	OFF
3	ON	ON	OFF	OFF	OFF
4	OFF	OFF	ON	OFF	OFF
...					

Table 1: DIP switch S1 for VPI address

3.4 Connection of the supply voltage

The supply with auxiliary power (electrical connection) takes place via a 2-pole header plug on the underside of the VPI. The respective 2-pole connection cable is included within the scope of supply.

A 12 V direct current is necessary for the power supply of the VPI. The FAFNIR VPI-Supply (art. no. 908315) is provided as an accessory. The VPI-Supply can supply up to two VPIs.

 **A minimum distance of 50 mm (thread measure) should be ensured between the VPI and the VPI-Supply.**

Alternatively, another power supply can be used. Therefore, a power consumption of 125 mA should be set for every VPI. The tolerance of the supply voltage must not exceed 5 %.

 **If the FAFNIR VPI-Supply is not used for the power supply of the VPI, it is imperative that the sensors and the VPI are correctly integrated into the potential equalisation (PA).**



3.5 Status LEDs

There are one green LED and two red LEDs on the VPI.

The green LED which is marked with "power", signals that the power supply is active and the VPI is ready for operation.

The red LED which is marked with "RS-485", signals incoming data from the higher-level system.

The red LED which is marked with "sensor", signals feedback from the sensors.

4 Technical data

4.1 VPI

The terminals are numbered with the figures 1 ... 8 and the additions +, A, B and - .

The intrinsically safe sensor circuits are safely galvanically isolated from the auxiliary power circuit for the use of a VPI-Supply up to a peak of 375 V of the nominal voltage.

The intrinsically safe sensor circuits are safely galvanically isolated from the control circuit up to a peak of 190 V of the nominal voltage.

Explosion protection	 II (1) G [Ex ia Ga] IIC			
EC type approval certificate	TÜV 10 ATEX 388544 X			
Permissible ambient temperature:	-20 °C to +60 °C			
Auxiliary power (Terminals located at the rear)	Direct current 12 V ± 5 %; approx. 125 mA, $U_m = 375$ V			
Sensor circuits (Terminals + A B -)	Intrinsic safety ignition protection class [Ex ia Ga] IIC (linear output characteristic) Maximum values $U_o = 10.5$ V $I_o = 41.0$ mA $P_o = 99.8$ mW			
Explosion protection group	IIC		IIB	
Permitted external inductance L_o	≤ 5 mH	≤ 2 mH	≤ 20 mH	≤ 10 mH
Permitted external capacity C_o	≤ 610 nF	≤ 780 nF	≤ 2.5 μF	≤ 3 μF
Measurement and control circuits (Plug connector S1)	Interface circuit $U_N = 5$ V Maximum safe voltage $U_m = 190$ V			

Table 2: Technical data VPI

4.2 VPI--Supply

Two VPIs can be connected to one VPI-Supply unit.

Explosion protection	 II (1) G [Ex ia Ga] IIC
EC type approval certificate	TÜV 10 ATEX 388544 X
Permissible ambient temperature:	-20 °C to +60 °C
Power supply (Terminals L, N, PE)	Alternating voltage 40 ... 60 Hz 230 V ± 10 %; approx. 4 VA, $U_m = 253$ V 115 V ± 10 %; approx. 4 VA, $U_m = 130$ V 24 V ± 10 %; approx. 4 VA, $U_m = 30$ V
Output voltage	12 V DC, ± 5 %, 250 mA

Table 3: Technical data VPI-Supply

5 List of figures

Figure 1: VPI terminals.....	8
------------------------------	---

6 List of tables

Table 1: DIP switch S1 for VPI address	9
Table 2: Technical data VPI.....	11
Table 3: Technical data VPI-Supply.....	12

7 Annex

7.1 Operating instructions VPI transducer

Edition: 11.2010

I Range

The corresponding equipment for the VPI and VPI-Supply may only be used outside the potentially explosive area.

The voltage supply for the VPI-Supply serves as powering the VPI transducer. The purpose of the VPI transducer is preferably to supply the electronic filling level sensors with power and transmit the measurement data to a higher-level analysis system.

II Standards

See EC type examination certificate.

III Instructions for safe ...

III.a ... use

The corresponding VPI equipment has eight intrinsically safe sensor inputs. Each sensor is connected using four terminal clamps. Two clamps are provided for the intrinsically safe power supply whilst the other two are for the transmission of measurement data. At the same time, the VPI transducer is used to safely isolate intrinsically safe and non-intrinsically safe circuits. All sensor connections are galvanically connected to one another.

The intrinsically safe sensor circuits of the VPI transducer are safely galvanically isolated from the auxiliary power supply circuit up to a peak of 375 V of the nominal voltage.

The non-intrinsically safe control-circuit (RS-485 interface) is linked to a 4-pole connector plug. This connector establishes the connection to a higher-level data processing system. The intrinsically safe sensor circuits of the VPI transducer are galvanically isolated from this measuring and control circuit up to a peak of 190 V of the nominal voltage.

III.b ... Installation

All wiring operations must be carried out with the power disconnected. The specific EN directives and local installation regulations including EN 60079-14 must be observed. The wiring from the sensor to the control unit shall be carried out using a four-wire cable (preferably blue). The terminals +, -, A and B on the sensor must be connected to the same terminals on the transducer.

If the VPI-Supply is not used to power the VPI transducer, it is imperative that the sensors and the transducers are integrated correctly into the potential equalisation (PA). The PA terminal is located in the middle of the VPI printed circuit board. All sensors must be securely connected with the PA terminal of the VPI transducer. The specific construction regulations must be observed.

III.c ... Assembly

The VPI transducer and the VPI-Supply must be installed in a case with a protection class of at least IP20. It is important to ensure that non-intrinsically safe wiring connections are located with a clearance of at least 50 mm (thread measure) from the VPI printed circuit board and the intrinsically safe sensor terminals. This can also be achieved using suitable separation plates for example.

III.d ... Commissioning

Before commissioning, all devices must be checked to determine that they are correctly connected and working properly. The power supply, including that of downstream devices, must also be checked.

III.e ... Maintenance, servicing and repair

The device is maintenance-free. In case of a defect, please send the transducer back to the manufacturer.

Special conditions



- 1 If the VPI-Supply is not being used, the sensors and the PA terminal on the VPI printed circuit board must be securely integrated with one another in the potential equalisation (PA).
- 2 The VPI transducer and the VPI-Supply must be constructed in a case which has a protection class of at least IP20.
- 3 When installing the VPI and the VPI-Supply, a clearance distance of at least 50 mm (thread measure) should be ensured between the two.
- 4 The VPI transducer and the VPI-Supply are designed for use in ambient temperatures of -20 °C ... +60 °C .

IV Labelling

VPI--Supply

- 1 Manufacturer: FAFNIR GmbH, Hamburg
- 2 Type designation: VPI-Supply
- 3 Serial Number:
- 4 Certificate Number: TÜV 10 ATEX 388544 X
- 5 CE marking:  0044

VPI

- 1 Manufacturer: FAFNIR GmbH, Hamburg
- 2 Type designation: VPI
- 3 Serial Number:
- 4 Certificate Number: TÜV 10 ATEX 388544 X
- 5 Ex marking:  II (1) G [Ex ia Ga] IIC
- 6 CE marking:  0044
- 7 Electrical Data: See operational manual for electrical data.

V Electrical Data

VPI-Supply

The auxiliary power supply of the VPI-Supply is connected to the terminals PE, N and L. Depending on the design of this module, the auxiliary power supply is

$$U = 24 \text{ V AC, } 115 \text{ V AC, or } 230 \text{ V AC, } \pm 10 \%, 40 \dots 60 \text{ Hz, } \sim 4 \text{ VA.}$$

The safe maximum voltage is

$$U_m = 30 \text{ V at } 24 \text{ V AC, resp.}$$

$$U_m = 130 \text{ V at } 115 \text{ V AC, resp.}$$

$$U_m = 253 \text{ V at } 230 \text{ V AC, resp.}$$

The output voltage is 12 V DC, $\pm 5 \%$

Two VPI transducers can be connected to one VPI-Supply.

VPI

The auxiliary power supply for the VPI transducer is connected to a plug underneath the module and equals:

$$U = 12 \text{ V DC, } \pm 10 \%, < 2 \text{ W.}$$

The safe maximum voltage is

$$U_m = 253 \text{ V.}$$

The sensor circuits are designed in the ignition protection "intrinsic safety" class [ia] with a linear output characteristic. The output values are:

$$U_o \leq 10.5 \text{ V}$$

$$I_o \leq 41.0 \text{ mA}$$

$$P_o \leq 99.8 \text{ mW}$$

	IIC		IIB	
Permitted external inductance L_o	$\leq 5 \text{ mH}$	$\leq 2 \text{ mH}$	$\leq 20 \text{ mH}$	$\leq 10 \text{ mH}$
Permitted external capacity C_o	$\leq 610 \text{ nF}$	$\leq 780 \text{ nF}$	$\leq 2.5 \text{ } \mu\text{F}$	$\leq 3 \text{ } \mu\text{F}$

The terminals are numbered with the figures 1 ... 8 and the additions +, A, B and - .

The intrinsically safe sensor circuits are safely galvanically isolated from the auxiliary power supply circuit up to a peak of 375 V of the nominal voltage.

The intrinsically safe sensor circuits are safely galvanically isolated from the control circuit up to a peak of 190 V of the nominal voltage.

Translation

(1) **EC-Type Examination Certificate**

- (2) Equipment and protective systems intended for use in potentially explosive atmospheres, **Directive 94/9/EC**

TUV NORD



- (3) **Certificate Number** **TÜV 10 ATEX 388544 X**

- (4) for the equipment: Measuring transmitter VPI with or without power supply
VPI-Supply

- (5) of the manufacturer: FAFNIR GmbH

- (6) Address: Bahrenfelder Str. 19
22765 Hamburg
Germany

Order number: 8000388544

Date of issue: 2011-01-20

- (7) This equipment or protective system and any acceptable variation thereto are specified in the schedule to this certificate and the documents therein referred to.
- (8) The TÜV NORD CERT GmbH, notified body No. 0044 in accordance with Article 9 of the Council Directive of the EC of March 23, 1994 (94/9/EC), certifies that this equipment or protective system has been found to comply with the Essential Health and Safety Requirements relating to the design and construction of equipment and protective systems intended for use in potentially explosive atmospheres given in Annex II to the Directive. The examination and test results are recorded in the confidential report No. 11203388544.
- (9) Compliance with the Essential Health and Safety Requirements has been assured by compliance with:

EN 60079-0:2009 **EN 60079-11:2007** **EN 60079-26:2007**

- (10) If the sign "X" is placed after the certificate number, it indicates that the equipment or protective system is subject to special conditions for safe use specified in the schedule to this certificate.
- (11) This EC-type examination certificate relates only to the design, examination and tests of the specified equipment in accordance to the Directive 94/9/EC. Further requirements of the Directive apply to the manufacturing process and supply of this equipment. These are not covered by this certificate.
- (12) The marking of the equipment or protective system must include the following:

II (1) G [Ex ia Ga IIC] IIC

TÜV NORD CERT GmbH, Langemarckstraße 20, 45141 Essen, accredited by the central office of the countries for safety engineering (ZLS), Ident. Nr. 0044, legal successor of the TÜV NORD CERT GmbH & Co. KG Ident. Nr. 0032

The head of the certification body

Schwedt

Hanover office, Am TÜV 1, 30519 Hannover, Fon +49 (0)511 986 1455, Fax +49 (0)511 986 1590

This certificate may only be reproduced without any change, schedule included.
Excerpts or changes shall be allowed by the TÜV NORD CERT GmbH

(13) **SCHEDULE**

(14) **EC-Type Examination Certificate No. TÜV 10 ATEX 388544 X**

(15) Description of equipment

The measuring transmitter VPI is used for the supply of intrinsically safe sensors which can be used in explosion hazardous areas. In addition, the measuring transmitter VPI is used for the transmission of electrical signals between the explosion hazardous area and non explosion hazardous area. Furthermore the measuring transmitter VPI is used as a module of a tank level measuring system. The measuring transmitter is made for a maximum of eight intrinsic safety channels.

For powering the measuring transmitter it can be used the power supply VPI-Supply. Also it can be used any other power supply under condition of safe use.

Electrical data

VPI with VPI-Supply

Supply circuit
(Terminals PE, N, L)

U = 24 V a.c., ± 10 %, 40 ... 60 Hz, ~4 VA or
U = 115 V a.c., ± 10 %, 40 ... 60 Hz, ~4 VA or
U = 230 V a.c., ± 10 %, 40 ... 60 Hz, ~4 VA

U_m = 30 V at 24 V a.c. resp.
U_m = 130 V at 115 V a.c. resp.
U_m = 253 V at 230 V a.c.

Communication interface RS485
(Terminals 1, 2, 3, 4)

U = ± 5 V
U_m = 100 V

Sensor circuits CH01 ... CH08
(Terminals +, A, B, -)

in type of protection Intrinsic Safety Ex ia IIC

Maximum values per circuit:

U_o = 10.5 V
I_o = 41 mA
P_o = 99.8 mW

Characteristic line: linear

Max. permissible external inductance L_o = 5 mH
Max. permissible external capacitance C_o = 610 nF

The intrinsically safety sensor circuits are safely galvanically separated from the communication terminal (RS485) up to a peak crest value of the voltage of 190 V and from the supply terminal up to a peak crest value of the voltage of 375 V.

Schedule EC-Type Examination Certificate No. TÜV 10 ATEX 388544 X

VPI without VPI-Supply

Supply circuit
(Terminals 1, 2)

$U = 12 \text{ V d.c., } \pm 10 \%, < 2 \text{ W}$
 $U_m = 253 \text{ V}$

Communication interface RS485
(Terminals 1, 2, 3, 4)

$U = \pm 5 \text{ V}$
 $U_m = 100 \text{ V}$

Sensor circuits CH01 ... CH08
(Terminals +, A, B, -)

in type of protection Intrinsic Safety Ex ia IIC

Maximum values per circuit:

$U_o = 10.5 \text{ V}$

$I_o = 41 \text{ mA}$

$P_o = 99.8 \text{ mW}$

Characteristic line: linear

Max. permissible outer inductance $L_o = 5 \text{ mH}$

Max. permissible outer capacitance $C_o = 610 \text{ nF}$

The intrinsically safety sensor circuits are safely galvanically separated from the communication terminal (RS485) up to a peak crest value of the voltage of 190 V.

(16) Test documents are listed in the test report No. 11203388544.

(17) Special conditions for safe use

1. The potential equalization terminal (PA) on printed circuit board of the measuring transmitter VPI has to be connected with the potential compensation of the explosion hazardous location when the power supply VPI-Supply is not used.
2. The measuring transmitter VPI and the power supply VPI-Supply has to be installed in an enclosure with degree of protection according to EN 60529 of minimum IP20.
3. At installation of the measuring transmitter VPI with the power supply VPI-Supply the minimum clearance between these two has to be 50 mm (tight string length).
4. The permissible ambient temperature range of the measuring transmitter VPI and of the voltage supply VPI-Supply is $-20 \text{ }^\circ\text{C}$ to $+60 \text{ }^\circ\text{C}$.

(18) Essential Health and Safety Requirements

no additional ones