

Corrective Control with VAPORIX-PCM

Preliminary Technical Information ⁽¹⁾

Functional Principle

VAPORIX-PCM (**P**ulse **C**orrection **M**odule) is a control module for pulse controlled vapour recovery systems which can correct physically caused drift effects of the vapour recovery rate (e.g. through temperature variations or swelling hoses and seals). VAPORIX-PCM receives the information regarding the necessary corrections from VAPORIX-Control.

VAPORIX-Control saves the data of each filling process in an internal history data base. Thus it is able to recognize drift effects in good time and to pass the necessary corrective information to VAPORIX-PCM which in turn generates corrected control pulses for the vapour recovery system. This way the vapour recovery system is no longer controlled with fuel flow pulses but with the corrected control pulses of VAPORIX-PCM.

The advantage of this history based corrective control system compared to a regulating system lies in the difference between physically based fluctuations in the vapour recovery rate and real errors in the vapour recovery system. The recognition of these real errors by means of the history evaluation makes possible the proper execution of the necessary maintenance according to BImSchV.

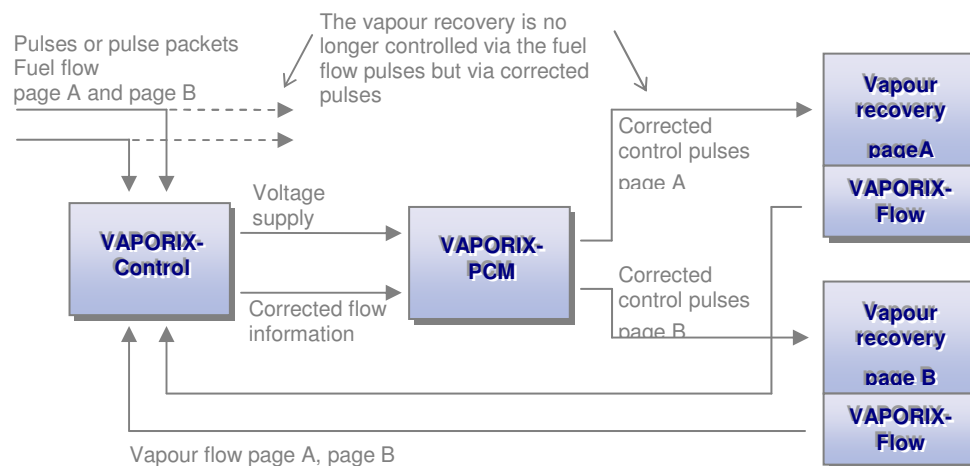

drawing 1: functional principle of the corrective control

Retrofitting of VAPORIX-PCM

The corrective control with VAPORIX-PCM is extremely suitable for new installations as well as for retrofitting:

- Due to its very small dimensions it can be applied in confined spaces.
- The exchange of components in an existing vapour recovery system is not required.
- An interference in the calibrated area of the pump is not necessary.
- Suitable for operation in all common pulse controlled vapour recovery systems since it is independent of all manufacturer specific features (e.g. calibration data).
- Simple installation and supply through VAPORIX-Control.
- Even with an already existing VAPORIX monitoring system it can be retrofitted without an exchange of components. The necessary firmware update of VAPORIX-Control can be carried out on location with a notebook.

(1) : subject to technical alterations.

Structure and Connection

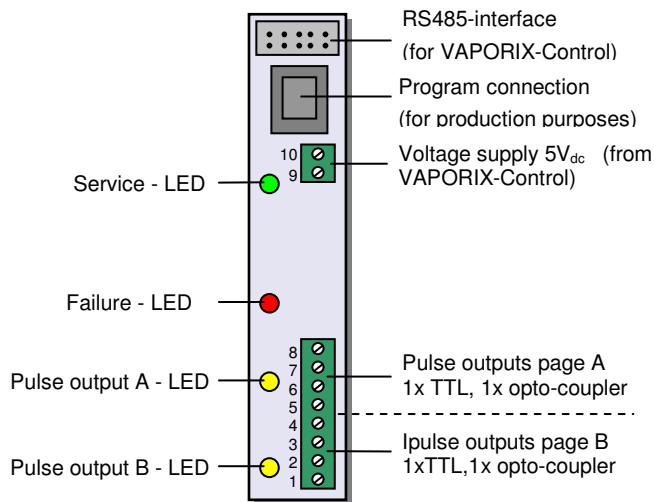

Drawing 2: connections and displays of VAPORIX-PCM

- Service – LED (green)
Flashes constantly: normal operation.
Short flashes once per second: Uncorrected operation (Dongle position 7).
- Failure – LED (red)
1 x flash: pulse frequency cannot be generated, since outside the valid range of 2,00 Hz ... 200,00 Hz.
2 x flashes: received unknown control order via RS485.
3 x flashes: faulty RS485 data transmission.
4 x flashes: received no data from VAPORIX-Control for over 60 seconds.
- Pulse output – LEDs (yellow)
Show pulse generation on page A and B.

Pin Configuration

10	Supply		+5 V
9			⊥
8	pulse page A	opto-coupler output	collector
7			emitter
6		TTL- output	+
5			⊥
4	pulse page B	opto-coupler output	collector
3			emitter
2		TTL- output	+
1			⊥

Preliminary Technical Data

Supply:	$5V_{dc}, \leq 30mA$ (from VAPORIX-Control), internal pole protection up to $30V_{dc}$, screw terminal for max. 1 mm ² . Connecting cable to VAPORIX-Control is part of the supply package.
Pulse outputs per side:	1 x TTL-compatible (4,7 V / 2 mA), short-circuit proof. 1 x Opto-coupler for generating galvanic separated pulses via external voltage source, collector and emitter open, max. switching voltage 28 V _{dc} , internal pole protection up to 30 V _{dc} . Screw terminal for max. 1 mm ² . Display of pulse generation via yellow LED.
Pulse frequencies:	2,0 Hz .. 200,00 Hz Corresponds to 2,4 l/min (at 50 Imp./l) to 60,0 l/min (at 200 Imp./l).
Serial interface:	RS485, 4-wire, 10-pole pillar plug-in connection, connecting cable to VAPORIX-Control is part of the supply package.
Service display:	LED green
Failure display:	LED red
Dimensions (l x b x h):	105 mm x 24 mm x 47 mm
Casing:	Module carrier for mounting DIN- carrier bars