

VISY-X

VISY-RF wireless system

Edition: 02/2010
Version: 8
Article no.: 207116



Table of contents

1	Introduction	4
1.1	In this manual.....	4
1.2	Requirements of service engineers.....	4
1.3	Safety precautions.....	4
1.4	Recommended tools	5
2	Components.....	6
3	Intended use	6
4	System installation	6
4.1	General installation diagram.....	6
4.2	Transmitter installation.....	7
4.3	VISY-Command RF installation	12
5	Commissioning	15
5.1	VISY-RFT-L radio transmitter.....	15
5.2	Procedure for checking radio signal quality.....	17
6	General notes and troubleshooting	20
6.1	Radio signal losses.....	20
6.2	Radio line of sight	20
6.3	Interference radiation	20
6.4	Equipment location	20
6.5	Fault codes and troubleshooting tips	21
6.6	Battery.....	21
7	Technical data.....	22
7.1	General.....	22
7.2	VISY-RFT-L radio transmitter.....	22
7.3	VISY-RFR receiver (in VISY-Command RF)	22
8	Appendix.....	23
8.1	EC Declaration of Conformity.....	23
8.2	VISY-RFT-L radio transmitter approval.....	24
8.3	Type approval certificate	25
8.4	Operating instructions.....	27
8.5	Figures	28
8.6	Tables	28

© Copyright:
 Reproduction and translation only with the written consent of the FAFNIR company. FAFNIR reserves the right to carry out product alterations without prior notice.

1 Introduction

The VISY-X system is a tank gauging system for fuel tanks at petrol stations. It comprises a series of VISY-Stick probes, which are fitted in the tank and linked to the VISY-Command control unit installed in the petrol station building. VISY-Command gathers data from the probes and transmits this on request to a higher-order system (e.g. PoS).

In most cases, the VISY-Stick probes will be linked electrically to the VISY-Command control unit by cable. With this set-up, the cable also supplies the VISY-Stick probes with power, which ensures a high level of data safety.

Sometimes, however, it may be that there are no more unused cable ducts available between the manhole and the VISY-Command. In this situation, the wireless system including the VISY-Command RF control unit is an attractive alternative because no excavation work is required. With the wireless system, a battery is used to supply power to the VISY-Stick probes and the VISY-RFT-L radio transmitters. The installation procedure for the VISY-RF wireless system is described on the pages that follow.

1.1 In this manual...

... you are guided through the installation and set-up of the VISY-RF wireless system.

These instructions contain a description of all the steps needed to perform the installation and commissioning of the wireless system.

During installation of the VISY-RF wireless system, it is necessary to configure the VISY-Command RF using the VISY-Setup configuration software. Please follow the appropriate instructions in the VISY-Setup instructions.



Useful information in these instructions that should be observed is printed in italics and marked with this symbol.

1.2 Requirements of service engineers





All parts of the VISY-RF wireless system should be installed only by trained service engineers.

1.3 Safety precautions

Observe and follow all product safety notes and operating instructions. The following safety precautions must be observed in order to reduce the risk of injury, the risk of electric shocks, fire or damage to the equipment:



This product should only be used in conjunction with FAFNIR components.

-  **Opening the cover on the VISY-Command RF unit could expose you to the risk of electric shock.**
-  **In the interests of explosion safety, only the use of original FAFNIR batteries is permitted.**
-  **The VISY-RFT-L radio transmitter must never be operated without the transmitter aerial connected.**
-  **Where external aerials are installed, all applicable rules and regulations governing lightning and surge voltage protection must be observed.**
-  **Make sure that the VISY-RFT-L radio transmitter in the manhole is never submerged in water.**

1.4 Recommended tools

- Laptop, RS 232 communication cable, VISY-Setup
- VISY-RF Meter, portable field-strength meter portable, 433.92 MHz (Art. No. 900090)

The VISY-RF Meter enables you to check for the presence and strength of a 433 MHz radio signal. During installation of the VISY-RF wireless system, this instrument is a useful means of determining the optimum position for the receiver aerial, of evaluating the signal strength of the VISY-RFT-L radio transmitter to be installed, and of identifying whether other radio signals may be present (interference radiation).

-  **Use of the VISY-RF Meter in potentially explosive atmospheres is strictly prohibited.**



To switch on the meter, press the button briefly. The instrument switches off automatically after two minutes. The series of LEDs indicate radio activity in the local area. The measured maximum field strength value is displayed for 1 second. The green area of the LED display indicates the presence of a strong radio signal, the red area of a weak radio signal.

The VISY-RF Meter is powered by a 9 V square battery (6LR61).

Figure 1: VISY-RF Meter

2 Components

The following components are required for the VISY-RF wireless system:

- VISY-Stick measuring probe
- VISY-RFT-L radio transmitter
- VISY-Command RF control unit with Interface VI-... and VISY-RFR receiver

The **VISY-RFT-L radio transmitter** is powered by an intrinsically safe battery pack.

The **VISY-RFR receiver** is sent data from the VISY-Stick probe by the VISY-RFT-L radio transmitter and then forwards the data to the Interface VI-... . The VISY-RFR receiver has a built-in 230 VAC power supply.

For installation of the **VISY-Stick and VISY-Command RF**, please refer to the most current edition of the following operating instructions:

VISY-Stick and VISY-Command VI-4 (or higher) Techn. Documentation – Art. No. 207145

3 Intended use

The VISY-RFT-L radio transmitter is approved for use in potentially explosive atmospheres.

VISY-Command RF must be installed outside the explosion hazard zone.

4 System installation

4.1 General installation diagram

Figure 2 below shows a typical petrol station layout. The VISY-Stick probe (1) is fitted inside the tank. The probe is linked to VISY-RFT-L radio transmitter (2) and receives its power from an intrinsically safe battery inside the transmitter. The radio transmitter generates radio signals, represented in the diagram by a series of arcs. These radio signals are received by an external aerial (3) and are forwarded to VISY-Command RF (4) along a 50-ohm coaxial cable. For viewing, the evaluated data can be forwarded to other peripheral equipment (VISY-View, PoS, BOS, etc.).

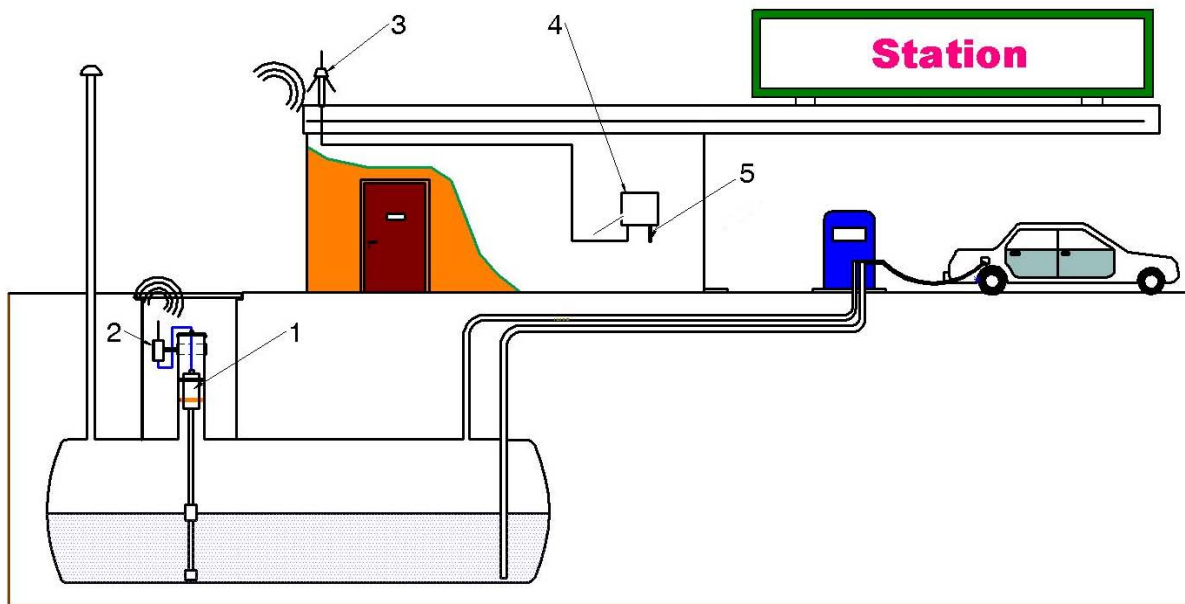

Figure 2: Typical layout of a petrol station

- 1 – VISY-Stick measuring probe
- 2 – VISY-RFT-L radio transmitter
- 3 – External VISY aerial (accessory)
- 4 – VISY-Command RF control unit
- 5 – VISY rod aerial (standard)



In any installation, you should determine the optimum position for the transmitter and receiver aerials so that the maximum possible field strength is achieved.

4.2 Transmitter installation

The VISY-RFT-L radio transmitter should be as unshielded as possible and fitted at the highest point possible inside the manhole so that the module remains functional even when there is water in the manhole. Figure 3 to 6 show the propagation patterns of radio waves under typical conditions.



The VISY-RFT-L radio transmitter must never be operated without the transmitter aerial connected.

4.2.1 VISY-Stick pipe installation (riser)

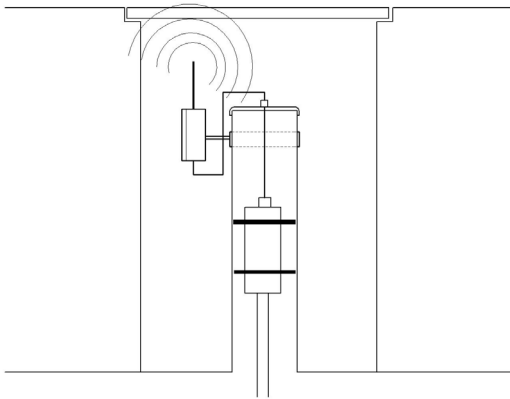

Figure 3: Manhole with plastic cover
Radio transmission with minimal attenuation

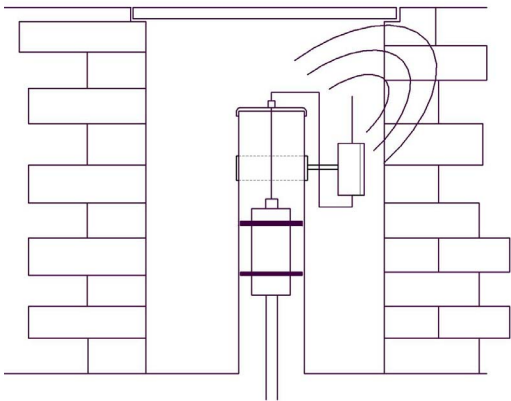

Figure 4: Walled manhole with metal cover
Radio transmission with significant attenuation

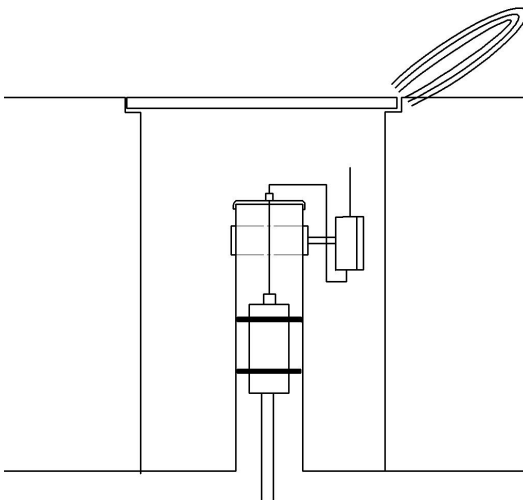

Figure 5: Welded (metal) manhole with metal cover
Strong shielding (Faraday cage); only a small part of the radio signal finds passage if a slot is present

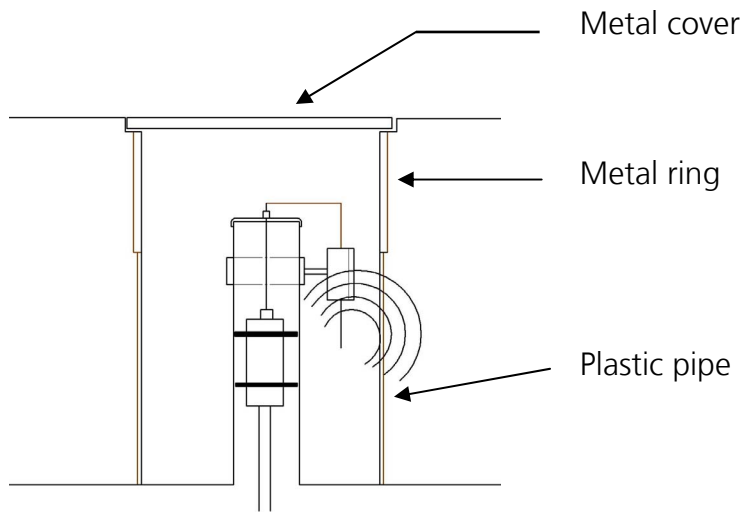

Figure 6: Manhole with metal ring and metal cover
Radio signal passes through the plastic pipe underneath the metal ring, moderate attenuation

4.2.2 VISY-Stick with screw-in unit

Figure 3 to Figure 6 similarly apply to installation of the VISY-RFT-L radio transmitter in conjunction with the VISY-Stick with screw-in unit.

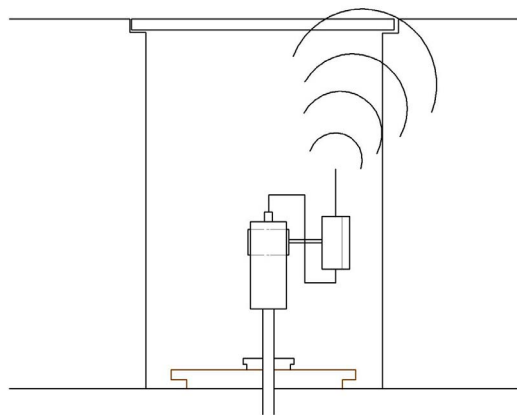

Figure 7: Manhole with plastic cover
Radio transmission with minimal attenuation

To install the VISY-Stick and the VISY-RFT-L, proceed as follows:

- Fit the VISY-Stick inside the pipe (riser) in the tank or using the screw-in unit (R 1½).

4.2.3 Commissioning the VISY-RFT-L radio transmitter

- The VISY-RFT-L radio transmitter is equipped with a 4-core cable and M12 connector.

- For installations with screw-in unit, the M12 connector can be connected directly to the VISY-Stick. First tighten the union nut of the M12 connector by hand and then tighten it further through 180° using a spanner.
- For installations with pipe installation (riser), there must be a cable gland present in the seal cap of the pipe cover. The connection cable can be disconnected from the radio transmitter and fed through the cable gland in the pipe cover.
- Screw the transmitter aerial into the relevant thread on the radio transmitter.
- Open the cover of the VISY-RFT-L radio transmitter and connect the battery connector to the appropriate contacts (see Figure 9). Check that the LED lights up for three seconds as soon as the connector is connected. Place the silica gel back inside the housing and close the cover.
- It is possible to attach the VISY-RFT-L radio transmitter to a pipe using the VISY-RFT installation kit (Art. No. 910040). At first, the aerial should be aligned vertically. Final aerial alignment and orientation of the housing will be determined by the quality of radio transmission (see following section).

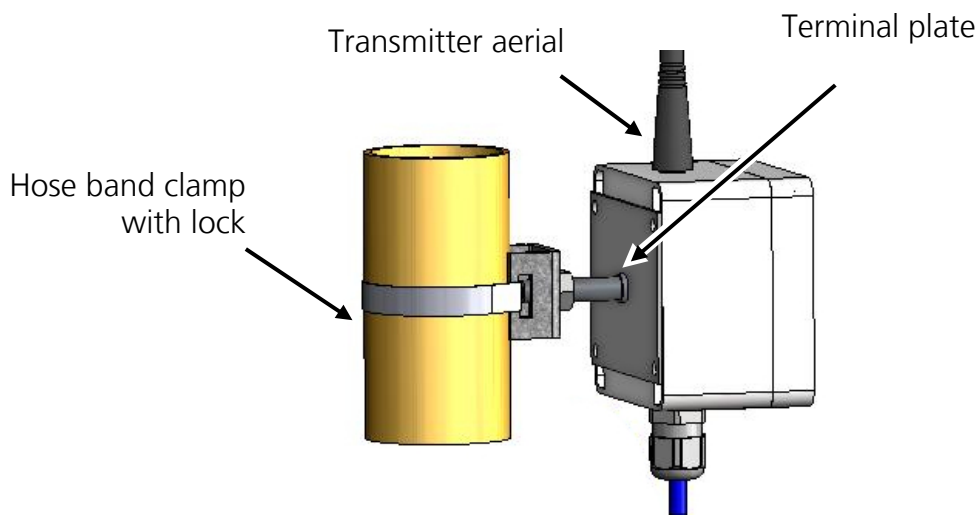

Figure 8: VISY-RFT installation kit



Make sure that the desiccant (silica gel) has been placed inside the VISY-RFT-L radio transmitter to prevent corrosion of the printed circuit boards.



In the interests of minimising data transmission interference, the radio path between radio transmitter and receiver aerial should be clear and unobstructed.

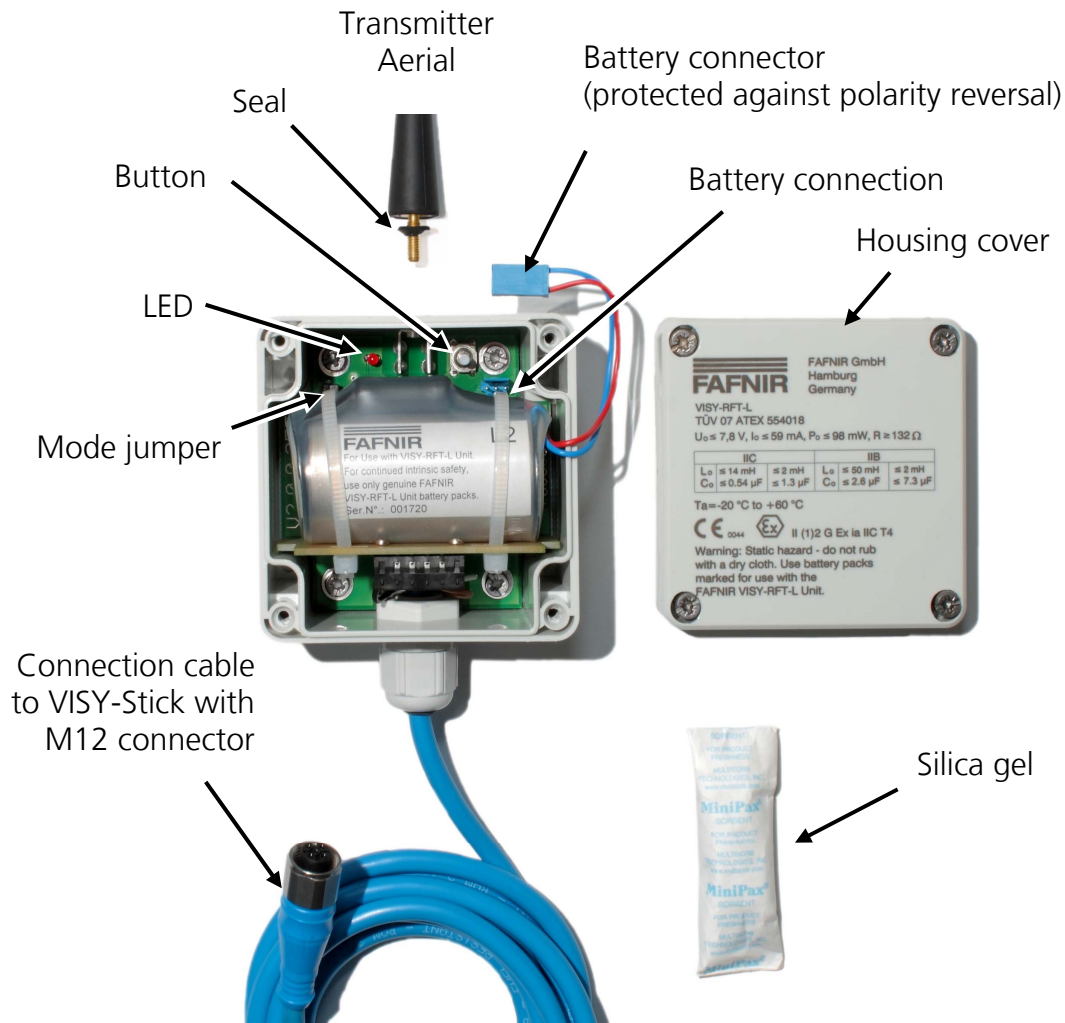

Figure 9: VISY-RFT-L radio transmitter with cover removed

4.3 VISY-Command RF installation

The VISY-RFR receiver is built into VISY-Command RF (4). The supplied rod aerial (5) connects directly to the BNC connector. To improve the reliability of transfer, an external aerial (3), which connects to the VISY-Command RF, is also required. In large installations, it is advisable to install a second external aerial in place of the rod aerial (5).



Observe local building regulations concerning external aerials.

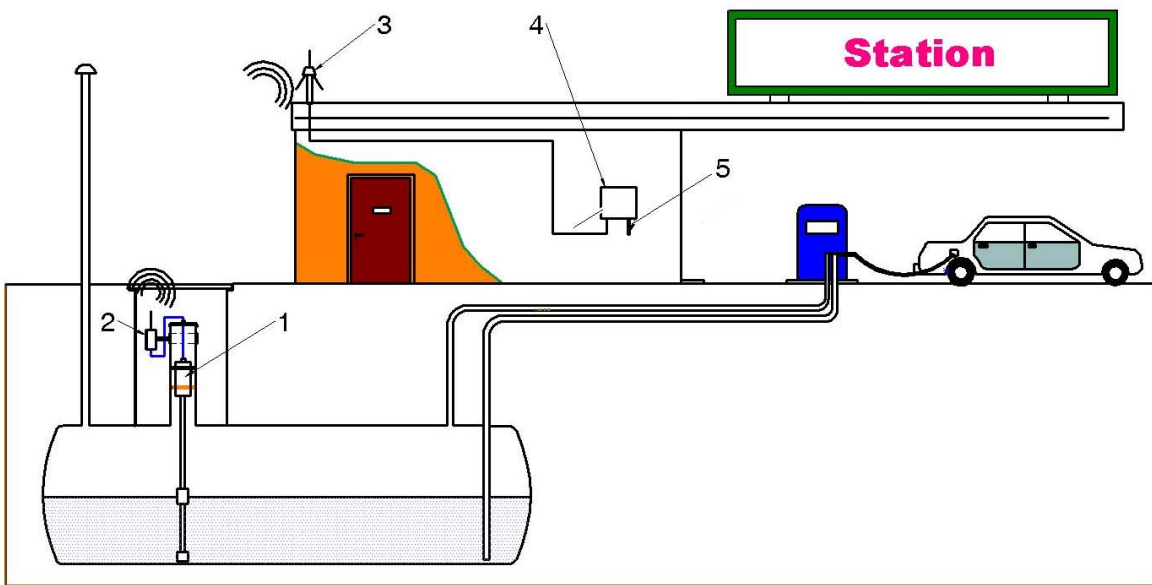

Figure 10: RF receiver with receiver aerial directly connected

4.3.1 External aerial for the receiver

The external FAFNIR aerial (Art. No. 900072) with spherical directional characteristic is supplied with a 2.5 m 50 ohm coaxial cable.



Figure 11: FAFNIR aerial

The external aerial can be mounted on a wall near the VISY-Command RF and positioned for optimum reception (see Figure 12).

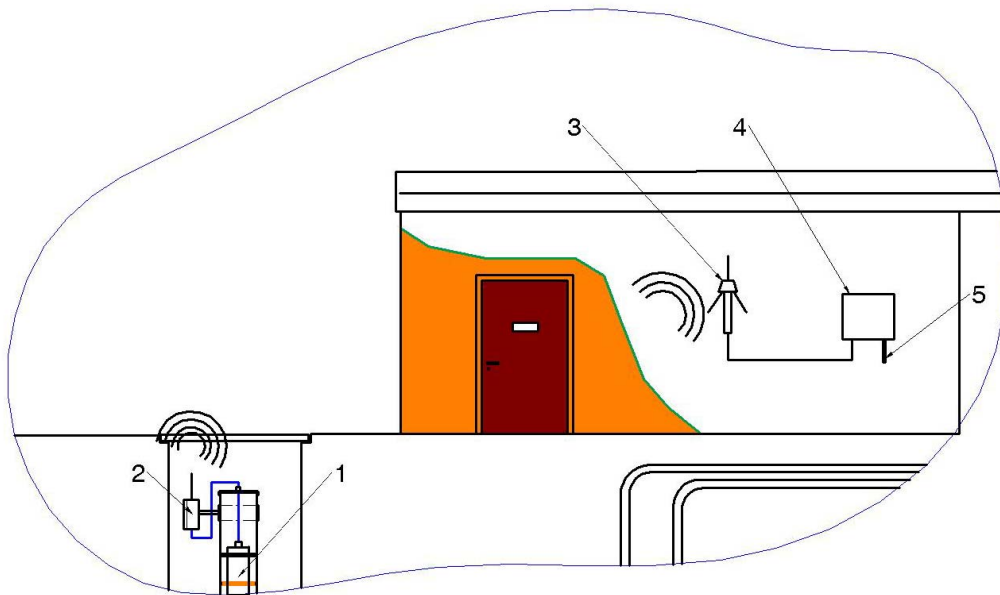

Figure 12: External receiver aerial with standard cable

If this situation proves unsatisfactory, it is possible to site the external aerial inside or outside the building as close as possible to the location of the VISY-RFT-L radio transmitters as shown in the diagram below (see Figure 13).

A coaxial cable extension may be required. The maximum permissible attenuation of the coaxial cable should not exceed 30 dB. To establish the connection, we recommend the use of the special 50 Ω low-attenuation aerial cable RG 213 (Art. No.: 900082) with BNC crimp connector and adapter (Art. No.: 900083).

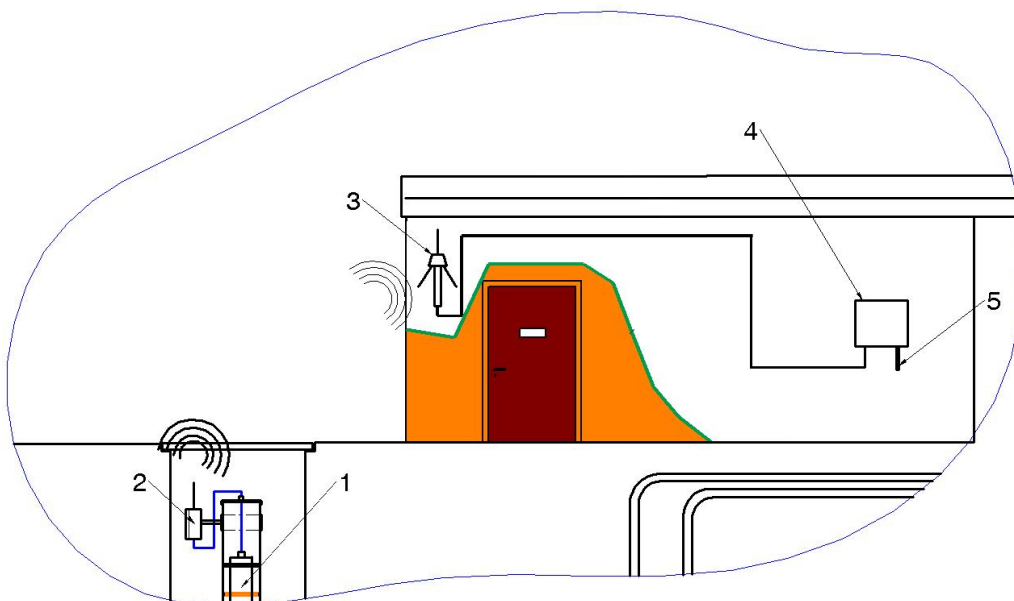

Figure 13: External receiver aerial with coaxial cable extension

Reception quality can be further improved if a second receiver aerial is used in place of the supplied rod aerial. The aerial could, for example, be mounted on the petrol station building or canopy (see Figure 14).

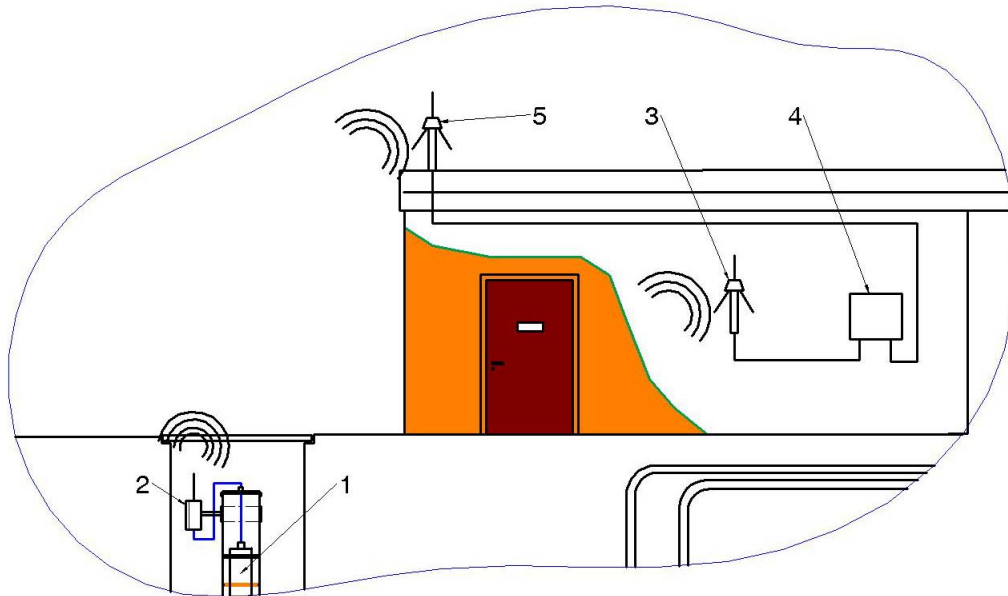

Figure 14: Two external receiver aerials

5 Commissioning

5.1 VISY-RFT-L radio transmitter

The VISY-RFT-L radio transmitter features two modes of operation:

- Service mode
- Normal mode with two transmission intervals (every minute or every five minutes).



Pressing the button toggles between service mode and normal mode.

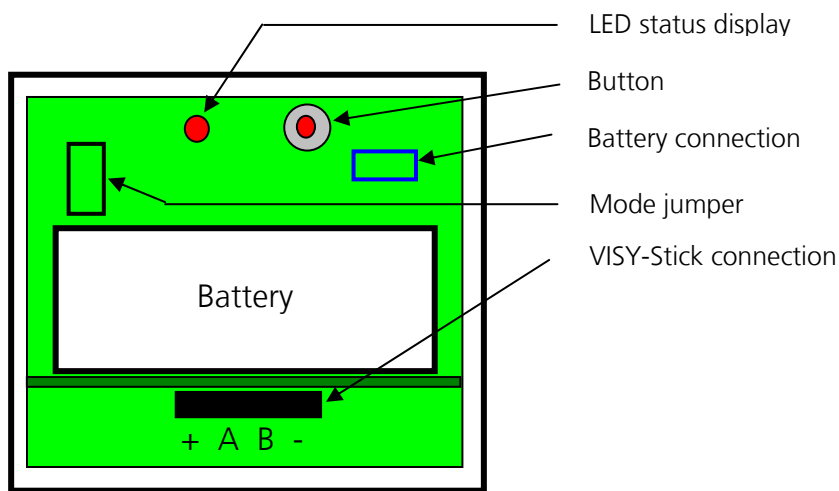
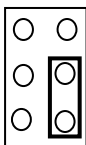

Figure 15: VISY-RFT-L radio transmitter; schematic diagram without cover

5.1.1 Mode jumper

1-minute mode



Transmits 3 data packets every minute

5-minute mode
(factory setting)

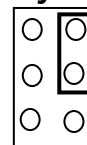

Transmits 6 data packets every five minutes

5.1.2 Service mode

After the system has been fully installed, it is necessary to check the quality of radio transmission. To do so, set the VISY-RFT-L radio transmitter to service mode by pressing the button. The locations of the button and LED indicator are shown in Figure 15.

As soon as you have pressed the button, service mode is indicated by the LED lighting up for two seconds. In this operating mode, one data packet is transmitted every two to five seconds. These short radio transmission intervals make it easier to check and correct the position of the aerials for optimum reception. Before each radio transmission, the LED flashes a specific number of times, depending on the status of the transmitter (see Table 1).

After approximately 30 minutes, the transmitter quits service mode automatically and returns to normal mode.

The system normally has more than one VISY-RFT-L radio transmitter installed. A collision of radio data packets is for the most part prevented by the VISY-RFT-L software.

5.1.3 Normal mode

In this mode of operation, the values measured by the VISY-Stick are transmitted either once every one or five minutes, depending on the position of the mode jumper (section 5.1.1).

In 1-minute mode, the VISY-RFT-L radio transmitter sends three identical radio data packets.

In 5-minute mode, the VISY-RFT-L radio transmitter sends six identical radio data packets.

The system normally has more than one VISY-RFT-L radio transmitter installed. A collision of radio data packets is for the most part prevented by the VISY-RFT-L software.

5.1.4 Status code

LED flashes ...	VISY-RFT-L radio transmitter status	VISY-Command RF status
1x	In operation	0
2x	No VISY-Stick connected	9
3x	Communication fault	8
4x	VISY-Stick fault	1, 5, 6 or 7

Table 1: Status message of the VISY-RFT-L radio transmitter

5.2 Procedure for checking radio signal quality

The field strength of the transmitters can be checked directly by viewing the status of VISY-Command RF in the VISY-Setup software application (based on the age of measured values and field strength parameters) (see Figure 16).



Figure 16: "Current Values" menu in VISY-Setup showing "Age of measured values", "RF Field Strength" and "Battery"

If the RF Field Strength field is showing at least one bar, the system is working correctly.

Now start the first transmitter in service mode and close the cover on the manhole concerned. If the data are still being received, this means that the reception conditions for this transmitter are satisfactory. It is now possible to check the field strength using the VISY-RF Meter. An input sensitivity of -80 dBm is recommended, but a minimum input sensitivity of -97 dBm is required.

If a satisfactory field strength is not detected, the receiver aerial is sited too far away or it is too heavily shielded. In this event, it will be necessary to find a better position inside or outside the building using the VISY-RF Meter (see section 1.4).

Figure 10 to Figure 13 in section 4.3 show the various possibilities. At this stage, the receiver aerial should be secured only provisionally because the reception conditions vary for each underground tank and must be acceptable for **all** transmitters.

Transmitters for which the minimum prerequisites are not fulfilled when the manhole cover is closed should be relocated inside their shaft or have their aerial alignment adjusted.

The potential for improving the quality of transmission from the manhole depends on the manhole's design (see section 4.2).

At the first attempt, the aerial should be fitted vertically (parallel to the receiver aerial). If the manhole has a metal cover, a horizontal aerial alignment may be more suitable. In this event, the horizontal aerial should always be aligned 90° to the line of sight first. Due to the abundance of possible reflections that occur inside an enclosed manhole, it may be that an aerial alignment angle other than 90° results in a stronger signal being received at the location of the receiver aerial.

- Masonry/concrete manhole with metal cover and frame: Due to the shielding effect of the metal cover, it may be better to site the transmitter deeper down the manhole. If this measure does not prove satisfactory, we recommend the use of an approved plastic cover.
- Manhole made of plastic tube with metal cover and metal tube towards the top: Due to the shielding effect of the metal tube, the transmitter should be sited at some point below inside the plastic section. If this measure does not prove satisfactory, we recommend the use of an approved plastic cover.
- Manhole in welded steel with metal cover and frame: Weaker signals from the manhole should be expected with this type of construction. One possible solution could be to replace the cover with an approved plastic cover. Another possibility would be to site the receiver aerial as close as possible to the transmitter aerial, i.e. on the canopy immediately above the cover, or to install the VISY-RFT-L radio transmitter outside the manhole (Figure 18). If the desired effect is still not achieved, it will be necessary to route a cable.



If an extension to the connection cable is required, the junction joining the cable ends must be established safely, i.e. with protection against water ingress. We recommend the use of our IP68 cable connector (Art. No.: 910035), for example.



Figure 17: IP68 cable connector

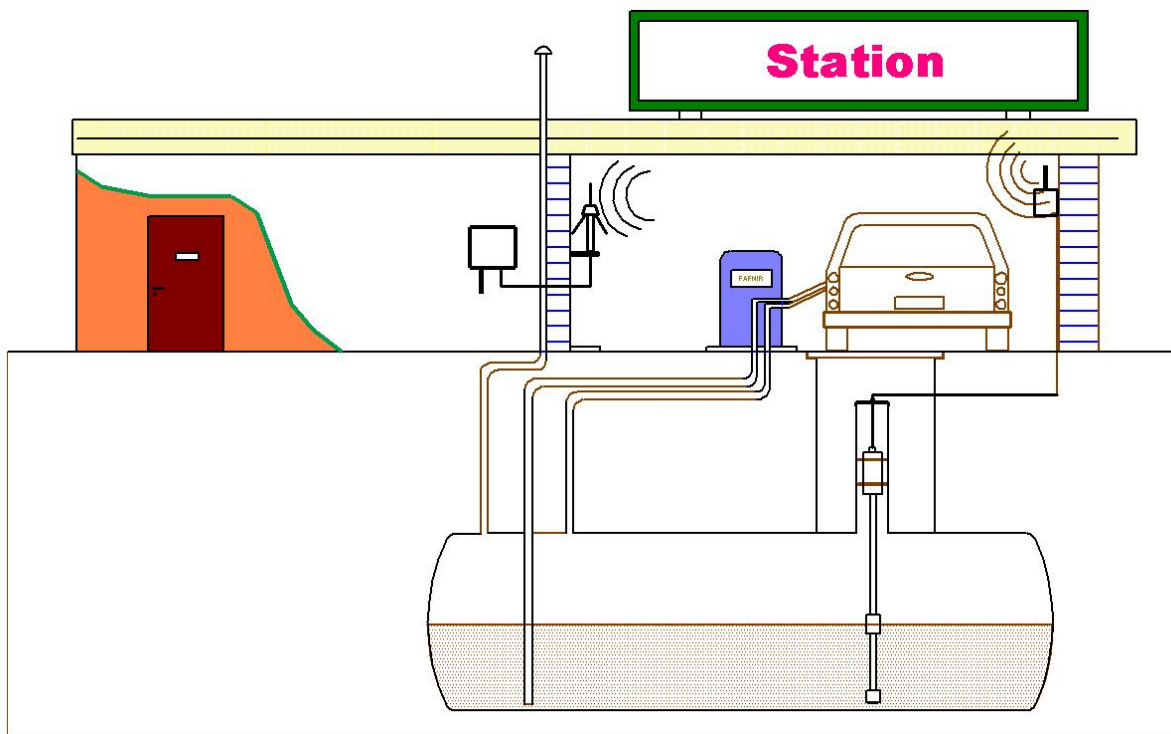



Figure 18: VISY-RFT-L radio transmitter installed outside the manhole

-  *Reception quality can be seriously affected by the presence of ice and snow on the manhole cover.*
-  *Reception quality can be seriously affected if the line of sight between manhole and receiver aerial is blocked by a vehicle.*

The procedure described should help to achieve satisfactory transfer properties in the majority of cases. When the data transfer quality of each tank probe has been checked, it is necessary to secure all components of the VISY-RF wireless system in their final position.

6 General notes and troubleshooting

6.1 Radio signal losses

Radio signals are influenced by the presence of objects along the propagation path. This must be taken into consideration when deciding on the optimum position for siting the aerials. Whenever a radio signal encounters an object, signal power is reduced because some of the signal is absorbed or reflected by the object and the wanted signal is weakened. This attenuation can vary with the type of object penetrated by the radio signal. Losses are significantly increased by objects that have a high metal content, for example.

- Price towers, dispensers, and other objects common to petrol stations, can lead to losses of 5 – 15 dB, depending on object size and material.
- Walls can cause losses of 10 – 30 dB, depending on type of construction.
- Bushes, trees or earth can be responsible for losses of 10 – 30 dB.

6.2 Radio line of sight

Radio line of sight refers to the clear, unimpeded signal path between transmitter and receiver. For the VISY-RF wireless system, every effort should be made to site the receiver aerial in direct line of sight of the manhole.

6.3 Interference radiation

Radio interference distorts or completely overlaps the received signal with the effect that it becomes impossible to evaluate. Interference radiation can be caused by devices nearby, e.g. transmitters on the same frequency.

6.4 Equipment location

The VISY-RFT-L radio transmitters should be mounted as high as possible in the manhole.

The receiver aerial should be installed in a position within direct line of sight of the manholes to enable unimpeded transfer of the radio signal. If possible, the aerial should be mounted in a corner to exploit the parabolic effect and improve reception.

6.5 Fault codes and troubleshooting tips

The fault codes below may be displayed by the VISY-Setup software application (see Figure 16). In VISY-Command RF, the same fault codes are represented by the two 7-segment LED displays.

Fault code	Description	Suggested solution
1-7	Problem with the VISY-Stick probe	See "VISY-Stick and VISY-Command" technical documentation
8	Bad connections between VISY-RFT-L and VISY-Stick	Check cable connections (M12 connectors)
9	No probe connected to VISY-RFT transmitter	Check connections and functional condition of VISY-Stick
10	No data available	Check connections inside VISY-Command RF between VISY-RFR and VI-Board
11	Communication fault	Check all components
13	Waiting for first data transfer	

Table 2: List of fault codes

6.6 Battery

The status of the battery can be checked using VISY-View or the VISY-Setup software application (see Figure 16). Five bars indicate that the battery is fully charged. Even if only one bar is displayed for the battery, the battery should still have sufficient charge to last a few weeks. However, the next battery change should be scheduled immediately to prevent failure of the VISY-RFT-L radio transmitter. If no bars are displayed, the battery has completely expired.



Battery performance is temperature-dependent. The battery operates only in the temperature range of -20 to +60 °C.



The battery should be replaced if the display is reporting that the battery is flat (≤ 1 bar).



It is permissible to replace the battery within the potentially explosive atmosphere (zone 1).



In the interests of explosion safety, only the use of original FAFNIR batteries is permitted.



Separate collection of electrical and electronic equipment: Batteries must be disposed at battery collection sites.



7 Technical data

7.1 General

Frequency	433.92 MHz
Signal path (line of sight)	max. 250 m

7.2 VISY-RFT-L radio transmitter

Radio power output	+8 dBm
Aerial	Lambda ¼ aerial with M4 set screw
Battery pack	Lithium
Battery capacity	VISY-RFT-L2 = 19 Ah
Expected battery life-time at 20 °C ambient temperature and average tank filling of 30 minutes/day	8 years (5-minute mode) 4 years (1-minute mode)
Housing	80 x 82 x 55 [mm]
Protection class	IP 67
Operating temperature range	-20 to +60 °C

7.3 VISY-RFR receiver (in VISY-Command RF)

Sensitivity	-107 dBm
Aerial connection	2 x BNC
Power supply	230 VAC ±10 %; 50 – 60 Hz
Output	1 W
Dimensions	137 x 75 x 52 [mm]

8.2 VISY-RFT-L radio transmitter approval

		FAFNIR GmbH Hamburg Germany	
VISY-RFT-L TÜV 07 ATEX 554018 $U_o \leq 7.8 \text{ V}$, $I_o \leq 59 \text{ mA}$, $P_o \leq 98 \text{ mW}$, $R_o \geq 132 \Omega$			
IIC		IIB	
L_o	$\leq 14 \text{ mH}$	$\leq 2 \text{ mH}$	$\leq 2 \text{ mH}$
C_o	$\leq 0.54 \mu\text{F}$	$\leq 1.3 \mu\text{F}$	$\leq 7.3 \mu\text{F}$
$T_a = -20 \text{ }^\circ\text{C}$ to $+60 \text{ }^\circ\text{C}$			
   II (1)2 G Ex ia IIC T4			
Warning: Static hazard - do not rub with a dry cloth. Use battery packs marked for use with the FAFNIR VISY-RFT-L Unit.			

Figure 19: Type plate for the VISY-RFT-L radio transmitter

Translation

(1) **EC-Type Examination Certificate**

TÜV NORD

- (2) Equipment and protective systems intended for use in potentially explosive atmospheres, **Directive 94/9/EC**



- (3) **Certificate Number** **TÜV 07 ATEX 554018**
- (4) for the equipment: Transmitting unit VISY-RFT-L...
- (5) of the manufacturer: FAFNIR GmbH
- (6) Address: Bahrenfelder Str. 19
22765 Hamburg
Germany
- Order number: 8000349281
- Date of issue: 2007-07-17

- (7) This equipment or protective system and any acceptable variation thereto are specified in the schedule to this certificate and the documents therein referred to.
- (8) The TÜV NORD CERT GmbH, notified body No. 0044 in accordance with Article 9 of the Council Directive of the EC of March 23, 1994 (94/9/EC), certifies that this equipment or protective system has been found to comply with the Essential Health and Safety Requirements relating to the design and construction of equipment and protective systems intended for use in potentially explosive atmospheres given in Annex II to the Directive. The examination and test results are recorded in the confidential report No. 07203349281.
- (9) Compliance with the Essential Health and Safety Requirements has been assured by compliance with:

EN 60 079-0:2006 EN 50 020:2002

- (10) If the sign "X" is placed after the certificate number, it indicates that the equipment or protective system is subject to special conditions for safe use specified in the schedule to this certificate.
- (11) This EC-type examination certificate relates only to the design, examination and tests of the specified equipment in accordance to the Directive 94/9/EC. Further requirements of the Directive apply to the manufacturing process and supply of this equipment. These are not covered by this certificate.
- (12) The marking of the equipment or protective system must include the following:

Ex II (1) 2G Ex ia IIC T4

TÜV NORD CERT GmbH, Langemarckstraße 20, 45141 Essen, accredited by the central office of the countries for safety engineering (ZLS), Ident. Nr. 0044, legal successor of the TÜV NORD CERT GmbH & Co. KG Ident. Nr. 0032

The head of the certification body

Schwedt

Hanover office, Am TÜV 1, 30519 Hannover, Fon +49 (0)511 986 1455, Fax +49 (0)511 986 1590

This certificate may only be reproduced without any change, schedule included.
Excerpts or changes shall be allowed by the TÜV NORD CERT GmbH

(13) **SCHEDULE**

(14) **EC-Type Examination Certificate No. TÜV 07 ATEX 554018**

(15) Description of equipment

The transmitting unit type VISY- RFT-L... is used to transfer data of the level measurement.

The permissible ambient temperature range is -20 °C to +60 °C.

Electrical data

Auxiliary power Nominal voltage 3.8 V
from built-in battery

Output circuit in type of protection "Intrinsic Safety" Ex ia IIC/IIB
(terminals +; A; B; -) resp. Ex ib IIC/IIB

Maximum values: $U_o = 7.8 \text{ V}$
 $I_o = 59.0 \text{ mA}$
 $R = 132.3 \text{ } \Omega$
 $P_o = 98.0 \text{ mW}$

Characteristic line: linear

C_i negligibly small
 L_i negligibly small

The maximum permissible value pairs of the external inductances (L_o) and capacitances (C_o) have to be taken from the following table:

	Ex ia IIC bzw. Ex ib IIC		Ex ia IIB bzw. Ex ib IIB	
L_o	14 mH	2 mH	50 mH	2 mH
C_o	0.54 μF	1.3 μF	2.6 μF	7.3 μF

(16) Test documents are listed in the test report No. 07203349281.

(17) Special conditions for safe use

none

(18) Essential Health and Safety Requirements

no additional ones

8.4 Operating instructions

Operating instructions

Edition: 07.2007

VISY-RFT-L... transmitter unit

Mode of operation

The VISY-RFT-L... transmitter unit is powered by a battery. The unit queries the measuring value sensor for its data periodically - the time interval depends on the selected mode of operation. The data are then transmitted along a unidirectional radio path.

Installation

The measuring value sensor is suitable for installation in zone 0, the VISY-RFT-L... transmitter unit in zone 1. The measuring value sensors available differ in their design, both mechanically and electronically.

Power supply



Voltage	$U_o \leq 7.8 \text{ V}$
Current	$I_o \leq 59 \text{ mA}$
Resistance	$R \geq 132.3 \Omega$
Power	$P_o \leq 98 \text{ mW}$
Capacitance	C_i negligible
Inductance	L_i negligible

	IIC		IIB	
External inductance	$L_o \leq 14 \text{ mH}$	$\leq 2 \text{ mH}$	$\leq 50 \text{ mH}$	$\leq 2 \text{ mH}$
External capacitance	$C_o \leq 0.54 \mu\text{F}$	$\leq 1.3 \mu\text{F}$	$\leq 2.6 \mu\text{F}$	$\leq 7.3 \mu\text{F}$

Type plate

The permanent marking specified by DIN EN 60079-0:2006 Section 29 was applied to the housing cover of the transmitter unit by means of the laser engraving method (type plate).

The type plate contains at least the following information:

Manufacturer:	FAFNIR GmbH, Hamburg				
Type designation:	VISY-RFT-L...				
Electrical data:	$U_o \leq 7.8 \text{ V}, I_o \leq 59 \text{ mA}, P_o \leq 98 \text{ mW}, R \geq 132 \Omega,$				
		IIC		IIB	
	$L_o \leq 14 \text{ mH}$	$\leq 2 \text{ mH}$	$\leq 50 \text{ mH}$	$\leq 2 \text{ mH}$	
	$C_o \leq 0.54 \mu\text{F}$	$\leq 1.3 \mu\text{F}$	$\leq 2.6 \mu\text{F}$	$\leq 7.3 \mu\text{F}$	
Max. ambient temperature	$T_A = -20 \text{ }^\circ\text{C}$ to $+60 \text{ }^\circ\text{C}$				
Marking:					
EC type approval certificate no.:	TÜV 07 ATEX 554018				
in accordance with EC Directive 94/9:	 0044  II (1) 2G Ex ia IIC T4				
Static charge:	Warning: Static hazard – do not rub with a dry cloth.				
Battery module:	Use battery packs marked for use with the FAFNIR VISY-RFT-L Unit.				

8.5 Figures

Figure 1: VISY-RF Meter	5
Figure 2: Typical layout of a petrol station	7
Figure 3: Manhole with plastic cover	8
Figure 4: Walled manhole with metal cover	8
Figure 5: Welded (metal) manhole with metal cover	8
Figure 6: Manhole with metal ring and metal cover	9
Figure 7: Manhole with plastic cover	9
Figure 8: VISY-RFT installation kit	10
Figure 9: VISY-RFT-L radio transmitter with cover removed	11
Figure 10: RF receiver with receiver aerial directly connected.....	12
Figure 11: Fafnir aerial	12
Figure 12: External receiver aerial with standard cable	13
Figure 13: External receiver aerial with coaxial cable extension.....	13
Figure 14: Two external receiver aerials	14
Figure 15: VISY-RFT-L radio transmitter; schematic diagram without cover.....	15
Figure 16: "Current Values" menu in VISY-Setup	17
Figure 17: IP68 cable connector	18
Figure 18: VISY-RFT-L radio transmitter installed outside the manhole.....	19
Figure 19: Type plate for the VISY-RFT-L radio transmitter.....	24

8.6 Tables

Table 1: Status message of the VISY-RFT-L radio transmitter	16
Table 2: List of fault codes.....	21